

**EFM/C SENSOR MODULE AND EDF5C NH<sub>3</sub> ELECTROCHEMICAL CELL**

Flameproof certified junction box and signal conditioning electronics including Electrochemical cell sensor housed in marine grade 316 stainless steel.



Certification: Flameproof to  $\text{Ex}$  II 2 G EEx d IIC T6

Operating Voltage: 15-32V

Linearity: <5% of nominal value

Range: 0-100, 0-500, 0-1000PPM

Selectivity: Highly selective to NH<sub>3</sub>, however as with all electrochemical cell sensors there is some cross sensitivity, see table.

<u>GAS</u>	<u>CONCENTRATION (PPM)</u>	<u>NH<sub>3</sub> PPM EQUIVALENT</u>
Hydrogen	1000	25
Nitrogen	100%	0
Chlorine	5	0
Carbon Monoxide	300	3
Carbon Dioxide	5000	0
Hydrogen Sulphide	10	0

For cross sensitivities of a particular gas contact EDL.

Operating Temperature Range: -20°C to +40°C

Operating Humidity Range: 15-90% Continuous  
0-99% Intermittent, Non-Condensing

Output: 4-20mA, 0-5Vdc

Response time: <40S to t<sub>90</sub>

Internal display: LED's (zero, 50% FSD and 100% FSD)

Calibration: Calibration by internal potentiometer

Zero Setting: Auto zeroing

**Calibration instructions**

1. At the EFM/C head electronics measure between the +VE and -VE Power input terminals and ensure the voltage is in the range 15V to 32V.
2. Ensure the sensor has been powered and allowed to stabilise for a minimum of 24 hours and that the zero lamp is on.
3. Using appropriate level of NH<sub>3</sub> in a balance of air check calibration of sensor, the Analogue output terminal has a range of 0-5V where 5V=FSD (full scale deflection). Adjust RV1 as necessary (clockwise increases sensitivity).
4. Whilst the EFM/C is indicating FSD ensure the ED710I is also indicating FSD.
5. Check all audio/Visual alarms operate.

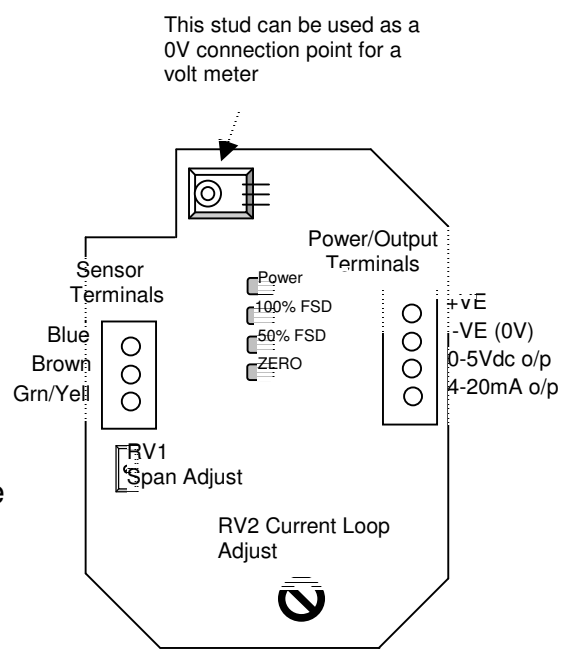

**NOTE**  
0-5V and 4-20mA outputs are with respect to 0V.

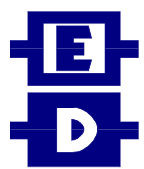

**ELECTRONIC DEVICES LIMITED**  
ENIGMA HOUSE, ENIGMA BUSINESS PARK, MALVERN WORCESTERSHIRE WR14 1GD ENGLAND.  
TELEPHONE: +44(0)1684 891500 FACSIMILE: +44(0)1684 891600 EMAIL: info@electronicdevice.demon.co.uk