

INSTRUCTION MANUAL

ED811 GAS DETECTOR

I N D E X

	<u>Page No.</u>
IMPORTANT NOTE	2
ATEX REQUIREMENTS	2
MARKING	3
GENERAL	3
INSTALLATION	4
SOLENOID VALVE	5
SENSORS	6
OPERATING INSTRUCTIONS	7
CALIBRATION - SEMICONDUCTOR	7
CALIBRATION – HEAD ELECTRONICS	8
DECLARATION OF CONFORMITY	10
ED811 EC-TYPE EXAMINATION CERTIFICATE	11
ZB EC-TYPE EXAMINATION CERTIFICATE	14

IMPORTANT

1. The equipment supplied must not be modified in any way since modifications will invalidate intrinsic safety certification.
2. Care should be taken during servicing as high voltages are present on base printed circuit board and may be present the output contacts.
3. It is important to note that the ED811 contains zener barriers, type ZB1, which are “potted” in epoxy resin. The zener barriers contain fuses which once damaged are not replaceable. The fuses inside the zener barrier will blow if even temporary short circuits are placed on the sensor wiring thus rendering the zener barrier inoperable and not repairable. Great care should therefore be taken to avoid inadvertent short circuits.
4. Electronic Devices strongly recommend consultation of the HSE publication EH40, which lists the permitted levels of exposure to most toxic gases.



ATEX ESSENTIAL SAFETY REQUIREMENTS

The ED811 gas detector, internally mounted Zener Barriers and associated gas sensors are ATEX certified Intrinsically Safe and the following important requirements need to be followed.

1. The equipment must only be installed, operated and maintained by trained competent personnel.
2. This apparatus has been designed in accordance with EN50 014 and EN50 020, therefore the apparatus has been designed to meet the fault tolerant requirements of Associate Apparatus for Category 'ia'.
3. The installation and maintenance must be in accordance with all appropriate international, national and local standard codes of practice and site regulations for intrinsically safe apparatus.
4. The installation and maintenance must be in accordance with the instructions contained in this installation and maintenance manual.
5. Access to the circuitry must not be made during operation.
6. This product is an associated electrical apparatus and must not be installed in the hazardous area without the provision of further certified hazardous area protection.
7. The product must not be subjected to mechanical and thermal stresses in excess of those permitted in the certification documentation and the instruction manual. If necessary the product must be protected by an enclosure to prevent mechanical damage.
8. The product must not be installed in a position where it may be attacked by aggressive substances.
9. The product must be protected from excessive dust by an enclosure etc.
10. The product can not be repaired by the user and must be replaced by an equivalent certified product. Repairs should only be carried out by the manufacturer or approved service centre.

MARKING

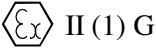
All units have a rating label which carries the following important information:-

Model type:	GAS DETECTOR TYPE ED811	
Input voltage:	110VAC/220VAC/240VAC	(delete as appropriate)
Vmax in;	Um: 250V	
Code:	[EEx ia] II C	
Certificate no.	Baseefa03ATEX0507	
Epsilon x, gas group and category:	 EEx II (1) G	
CE marking, Notified body number:	 CE 1180	
Serial no.	(serial number must be entered here)	
Year of construction:	(year of manufacture must be entered here)	

GENERAL

The ED811 is a fixed installation gas detection system which can detect a wide range of flammable and toxic gases dependent upon sensor type used.

The ED811 is designed for mains input voltage and it is important to ensure the input voltage of the control unit is the same as the supply available. Special consideration should be given to the "Hazardous Area common connection" terminal. This should normally be connected to a good quality earth suitable for intrinsically safe equipment. Attention is drawn to the need for correct cabling, particularly to the sensors located in the Hazardous Area. The cable supplied by EDL for use with the ED811 has been tested to ensure correct parameters, see installation section of this manual.

Attention is also drawn to the need for calibration soon after installation. When supplied alarm levels are approximately set for the target gas (if stated with order) so that a measure of immediate protection is obtained once correct operation has been ensured.

INSTALLATION

Note only EDL manufactured sensors, which are certified Intrinsically Safe, can be connected to the ED811 and fitted in the Hazardous Area. The ED811 control unit and all uncertified equipment should be located in the Safe Area only.

Control Unit: The unit should be mounted in a convenient position for the operator away from possible mechanical damage or ingress of moisture and allowing the clear hinged lid to swing open for ease of calibration etc.

The enclosure is fixed to a bulkhead with screws through one key hole and two fixed holes in the base. To obtain access to the two lower slotted holes remove the terminal cover.

Note it is not usually necessary to remove the front panel and PCB assembly during installation or calibration.

Only the relay contacts marked NON ALARM ACCEPT should be used for control functions as they will remain in the alarm state until the gas has cleared and the unit reset.

Sensor cable entry must only be made through the intended hole via either the standard rubber grommet or cable gland. Sensor cables must not cross or lie over each other or safe area cables see fig1 below.

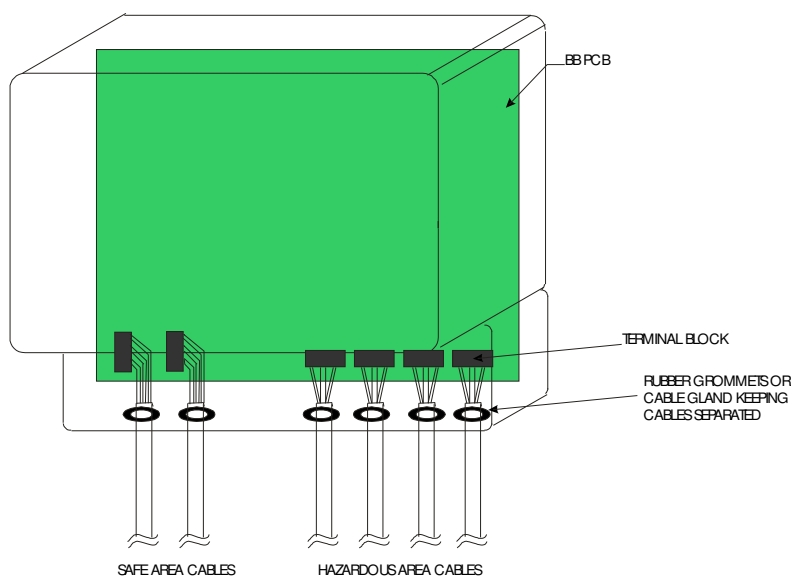
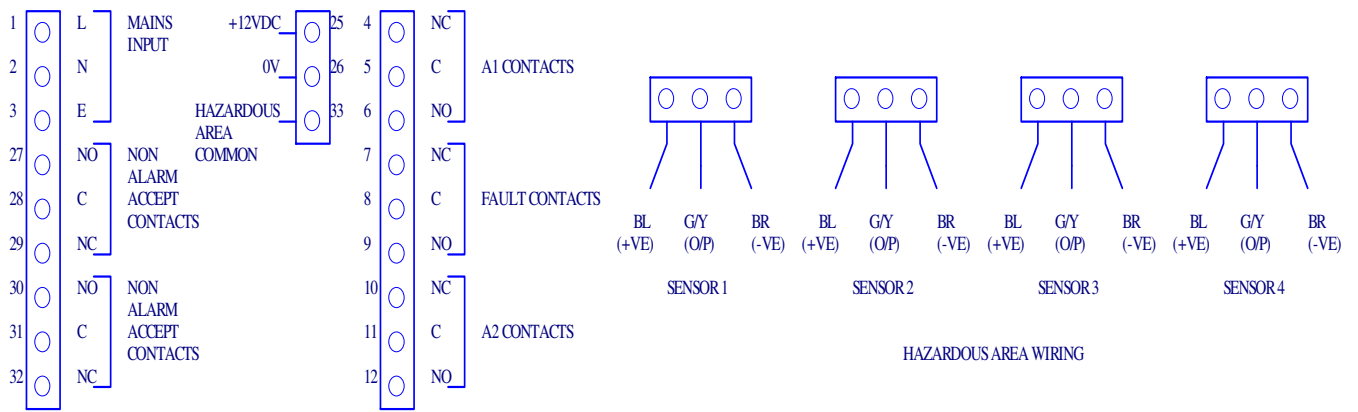

FIG 1

In addition to the zener barrier fuses (which cannot be replaced) each sensor is individually fused on the base board PCB. If a sensor fails to respond the nominal 5V between blue and brown terminals should be checked and the 160mA quick blow (F) changed if necessary.

Sensor Wiring: The Sensor cable should meet the following specification as listed in the Zener Barrier (ZB1) certificate, see page 16. The total capacitance of the cable must not exceed 6.8uF for EDS/C and EDS/P or 8.8uF for the EDF sensor. Also the inductance or inductance to resistance (L/R) ratio should not exceed 0.06mH or 14uH/ Ω respectively.



SAFE AREA WIRING

FIG 2

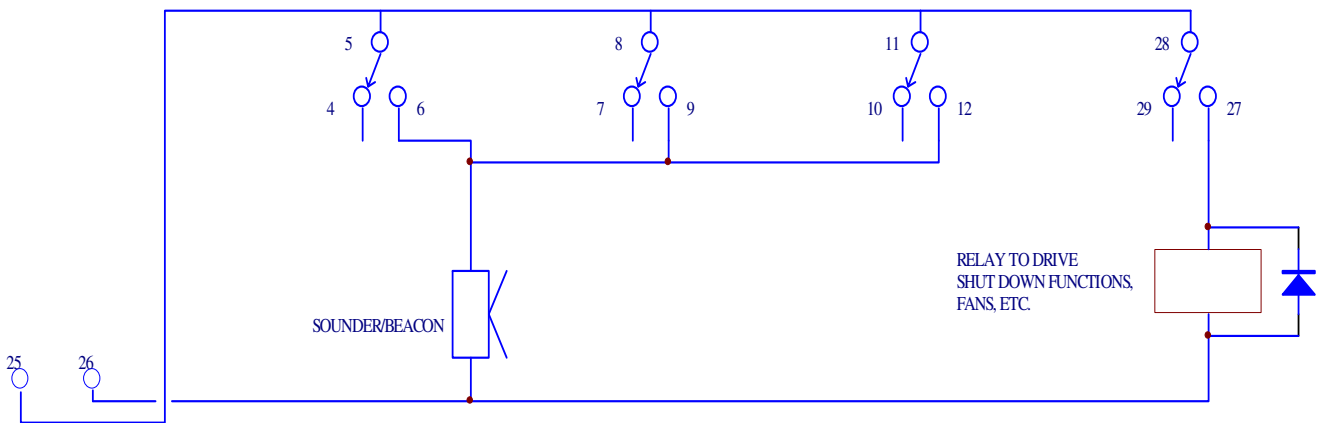

Relay contact rating: 2A at 240VAC Non Inductive

FIG 3

SENSORS

Type EDF 1B, 2B, 3B and 3Bfig are semiconductor elements housed in a certified flameproof stainless steel housing. The housing has a male M32 thread which can be screwed into a conduit or suitable junction box. The semiconductor sensors are available in the following types:-

- a) EDF1B flameproof.
Suitable for the detection of flammable gases such as Ammonia, Butane, Propane and some toxic gases, for more gases see list available.
- b) EDF2B flameproof.
Suitable for the detection of flammable gases such as Methane, Hydrogen and some toxic gases, for more gases see list available.
- c) EDF3B flameproof.
Suitable for the detection of most Freons such as R22.
- d) EDF3B fig flameproof
Suitable for the detection of most Freons such as R11, R12, R143A, R134A etc.

The EDS/C IS Transmitter is a intrinsically safe junction box complete with head electronics and electrochemical cell gas sensor suitable for the detection of various toxic gases. Many different electrochemical cells are available and EDL should be consulted to advise on correct sensor type.

The EDS/P IS Transmitter is a intrinsically safe junction box complete with head electronics and catalytic (pellistor) gas sensor suitable for the detection of flammable gases. Contact EDL for advice on correct sensor type.

Siting: The sensor heads should be placed lower than gas appliances when the gas to be detected is heavier than air. If the gas is lighter than air then the sensors should be placed above possible sources of leaks. Consideration should be given to the temperature of the gas at the time during a leak, for example if a serious Ammonia leak occurs in a refrigeration plant it can leak as a liquid and stay at floor level for some time even though Ammonia is lighter than air. In this instance sensors at low and high levels are normally fitted.

Attention should be given to the probable gas flow in each particular installation to site the sensors in the most advantageous position. In living quarters particular consideration should be given to carbon monoxide, it is advisable that some of the sensors are mounted at head height.

The sensors are sealed into their stainless steel enclosures and no attempt should be made to open them on site, if necessary they should be returned to EDL for repair/servicing.

Unused sensor positions: When all of the sensor positions are not being used the spare position should have the dip switches on the control PCB set to "standard sensors" and a terminating resistor of 47K Ω fitted to avoid the fault lights and relay operating. This is normally done before the unit leaves the factory as standard.

OPERATING INSTRUCTIONS

When power is first applied the power light should illuminate immediately. The A1 and A2 lights of semiconductor sensors will illuminate within a few seconds and will be ready to be reset after a few minutes, provided the sensors are in clean air. The alarm lights and relays latch and the reset switch must be pressed to clear any alarms.

The output functions can be easily tested by pressing the “alarm test” button. If the “alarm accept” button is pressed any sounders or beacons connected will be muted.

When the input supply drops so low as the control unit cannot function correctly the low voltage light will illuminate and the fault relay will activate.

Engineers override: should be used with caution as all ALARMS are disabled for a period of approximately 30minutes. A hidden switch is located to the left of the reset switch. Pressed through the front panel using a small screwdriver all Alarms are Isolated and the Fault Buzzer sounds. Operate the hidden switch to the right of the Reset switch (keeping it pressed for several seconds) and all Alarms will be returned to the operational state and the Fault Buzzer will silence.

CALIBRATION

Before dispatch the alarm levels are approximately set for the target gas (if stated with order) or set to 25% and 50% LEL butane so that a measure of immediate protection is obtained once correct operation has been ensured.

Once the sensors and control unit have been in operation for a minimum of 24 hours calibration can be attempted. Calibration should be repeated at least every twelve months with regular checks in between.

Calibration must take place in a clean air condition to ensure accuracy.

Semiconductor sensors:

1. Immerse the sensor in the correct concentration for the A1 alarm, if using a continuous flow do not use a flow rate of above 0.3L/min.
2. After allowing the sensor time to settle (10-20 seconds) adjust the appropriate potentiometer located under the A1 light, accessed through the front panel. Rotating clockwise increases sensitivity until the A1 light just illuminates, if the light comes on prematurely wind anticlockwise whilst continuously pressing the reset switch until the light goes out and then clockwise until it just illuminates.
3. Immerse the sensor in the correct concentration for the A2 alarm, if using a continuous flow do not use a flow rate of above 0.3L/min.
4. After allowing the sensor time to settle (10-20 seconds) adjust the appropriate potentiometer located under the A2 light, accessed through the front panel. Rotating clockwise increases sensitivity until the A2 light just illuminates, if the light comes on prematurely wind anticlockwise whilst continuously pressing the reset switch until the light goes out and then clockwise until it just illuminates.

Repeat for all semiconductor sensors fitted.

EDS/C and EDS/P Transmitters

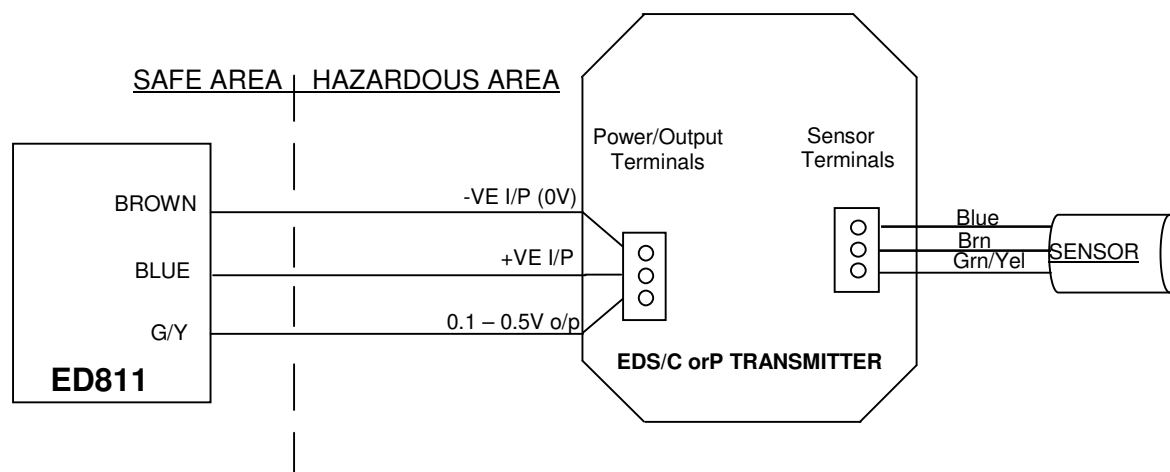

INITIAL SETUP

It is vitally important that the ED811 and EDS/C or P transmitter are calibrated together ensuring that the ED811 indicates an alarm at the correct concentration. After installation is complete the following setup procedure should be followed matching the EDS/C or P, ED811 and cable run together.

EDS/C

1. At EDS/C transmitter measure between – I/P and + I/P, ensure voltage reading is in the range 4.75 – 5.4V with a digital volt meter.
2. Using the correct calibration gas for your low alarm, ensure the calibration of the EDSC Transmitter using the EDSC calibration instructions. Whilst the EDSC is giving the correct output go to the ED811 control unit and adjust the A1 (located under the A1 light, accessed through the front panel) potentiometer until the A1 light just illuminates. Rotating clockwise increases sensitivity until the A1 light just illuminates, if the light comes on prematurely wind anticlockwise whilst continuously pressing the reset switch until the light goes out and then clockwise until it just illuminates.
3. Using the correct calibration gas for your high alarm, ensure the calibration of the EDSC Transmitter using the EDSC calibration instructions. Whilst the EDSC is giving the correct output go to the ED811 control unit and adjust the A2 (located under the A2 light, accessed through the front panel) potentiometer until the A2 light just illuminates. Rotating clockwise increases sensitivity until the A2 light just illuminates, if the light comes on prematurely wind anticlockwise whilst continuously pressing the reset switch until the light goes out and then clockwise until it just illuminates.

Example of calculating expected output voltage

The output of the EDSC* ranges from 0.1 to 0.5V (zero to full scale). If Full scale is 1000ppm NH₃ then :

250ppm output : $(0.4 \times 0.25 + 0.1) = 0.2V$

500ppm output: $(0.4 \times 0.5 + 0.1) = 0.3V$

1000ppm output: $(0.4 \times 1 + 0.1) = 0.5V$

EDS/P

1. At EDS/P transmitter measure between – I/P and + I/P, ensure voltage reading is in the range 4.0 – 5.4V with a Digital volt meter.
2. Using the Zero adjustment potentiometer on the EDS/P, rotate clockwise until the 50% lamp is just illuminated or 0.3V is measured on the O/P terminal w.r.t 0V.
4. Go to the ED811 Control unit and adjust the A1 potentiometer (located below the A1 light and accessed through the front panel) until the A1 light just illuminates. Rotating clockwise increases sensitivity until the A1 light just illuminates, if the light comes on prematurely wind anticlockwise whilst continuously pressing the reset switch until the light goes out and then clockwise until it just illuminates.
3. Back at the EDS/P again using the Zero adjustment potentiometer on the EDS/P, rotate clockwise until the 100% lamp is just illuminated or 0.5V is measured on the O/P terminal w.r.t 0V.
4. Go to the ED811 Control unit and adjust the A2 potentiometer (located below the A2 light and accessed through the front panel) until the A2 light just illuminates.
5. Using the EDS/P instructions return the output to Zero and calibrate the sensor.
Remember the Sensor requires a minimum of 24 hours to settle otherwise the calibration WILL NOT be accurate.

Example of calculating expected output voltage

The output of the EDSP* ranges from 0.1 to 0.5V (0 to full scale). If Full scale is 10,000ppm NH₃ then :

2,500ppm output : $(0.4 \times 0.25) + 0.1 = 0.2V$

5,000ppm output: $(0.4 \times 0.5) + 0.1 = 0.3V$

10,000ppm output: $(0.4 \times 1) + 0.1 = 0.5V$

* The output range stated is correct when the EDSC / EDSP is connected to the ED810, if tested separately the output range will be 0.2 to 1.0VDC.

Please note the - ED811 EC-TYPE EXAMINATION CERTIFICATE

And the ZB EC-TYPE EXAMINATION CERTIFICATE

Graphics have been removed to reduce the size of the document for download purposes.

The full manual and certificates can be obtained by contacting Electronic Devices Ltd.