

INSTRUCTION MANUAL

ZBD ZENER BARRIER

INDEX

	<u>Page No.</u>
INTRODUCTION	2
ATEX REQUIREMENTS	2
MARKING	3
SELECTION TABLE	3
MAINTENANCE	4
HAZARDOUS AREA EARTH CONNECTION	4
USE WITH AN OXYGEN SENSOR	5
USE WITH A FIRE DETECTION SYSTEM	6
USE WITH A EDSC TRANSMITTER	7
USE WITH A TYPE B GAS SENSOR	8
USE WITH A TYPE A GAS SENSOR	9
DECLARATION OF CONFORMITY	10
EC-TYPE EXAMINATION CERTIFICATE	11



ENIGMA HOUSE, ENIGMA BUSINESS PARK, MALVERN, WORCESTERSHIRE WR14 1GD ENGLAND.

TELEPHONE : + 44 (0) 1684 891500 FACSIMILE + 44 (0) 1684 891600 EMAIL: sales@electronicdevice.demon.co.uk WEB SITE: www.electronicdevice.demon.co.uk

Introduction

The ZBD modules allow the connection of safe area equipment, eg Fire Detector control unit, to devices in a Hazardous Area, eg intrinsically safe smoke heads. It is important that the equipment mounted in a Hazardous Area is certified for Hazardous Area use and, in particular, suitable for the appropriate gas group and temperature class.

Certain items can be classed as 'Simple Apparatus', eg switches, and installed in the Hazardous Area provided the Zener Barrier is chosen so that the matched output power of the device does not exceed 1.3W in a 40°C ambient, 1.2W in a 60°C ambient and 1.0W in an 80°C ambient, and then the simple apparatus would be classified as T4. Please see latest regulations for guidance before using the simple apparatus classification.

It is also important to install cable which is suitable for use in a Hazardous Area and, in particular, the cable's capacitance and inductance or L/R ratio must not exceed the values stated by BASEEFA for the particular Zener Barrier used.

Zener Barriers are always mounted in the Safe Area.

ATEX Essential Safety Requirements

1. The equipment must only be installed, operated and maintained by trained competent personnel.
2. This apparatus has been designed in accordance with EN50 014 and EN50 020, therefore the apparatus has been designed to meet the fault tolerant requirements of Associate Apparatus for Category 'ia'.
3. The installation and maintenance must be in accordance with all appropriate international, national and local standard codes of practice and site regulations for intrinsically safe apparatus.
4. The installation and maintenance must be in accordance with the instructions contained in the installation and maintenance manual.
5. Access to the circuitry must not be made during operation.
6. This product is an associated electrical apparatus and must not be installed in the hazardous area without the provision of further certified hazardous area protection.
7. The product must not be subjected to mechanical and thermal stresses in excess of those permitted in the certification documentation and the instruction manual. If necessary the product must be protected by an enclosure to prevent mechanical damage.
8. The product must not be installed in a position where it may be attacked by aggressive substances.
9. The product must be protected from excessive dust by an enclosure etc.
10. The product can not be repaired by the user and must be replaced by an equivalent certified product. Repairs should only be carried out by the manufacturer or approved repairer.

MARKING

All units have a rating label which carries the following important information:-

Model type: ZENER BARRIER TYPE ZBD1-7

Vmax in: Um: 250V

Temp: $-20^{\circ}\text{C} < \text{Ta} < 60^{\circ}\text{C}$

Code: [EEx ia] II C

Certificate no. BAS99ATEX7150

Epsilon x,
gas group
and category:  II (1) G

CE marking,
Notified body
number:  1180

Serial no. (serial number must be entered here)

Year of construction: (year of manufacture must be entered here)

The ZBD Zener Barriers are available in several voltage and resistance combinations, see below:

SELECTION TABLE

BARRIER TYPE	FUSE VALUE	ZENER DIODE	OUTPUT RESISTOR
ZBD1 ch.1*	200mA	7.5V	10 ohms
ch.2*	200mA	7.5V	39 ohms
ZBD2 ch.1*	200mA	7.5V	18 ohms
ch.2*	200mA	7.5V	18 ohms
ZBD3 ch.1*	63mA	20V	150 ohms
ch.2*	63mA	20V	150 ohms
ZBD4 ch.1*	200mA	7.5V	220 ohms
ch.2*	200mA	7.5V	220 ohms
ZBD5 ch.1*	200mA	7.5V	1K ohm
ZBD6 ch.1*	63mA	20V	180 ohms
ch.2*	63mA	20V	180 ohms
ZBD7 ch.1*	50mA	20V	270 ohms
ch.2*	50mA	20V	270 ohms

*Available in either positive or negative format

Contact EDL to ensure correct barrier choice is made.

The ZBD and ZBPD have internal, non-replaceable fuses and it is vital the unit is wired correctly before applying power.

The ZBPD has current limiting circuitry built into channel 1 to protect the fuse. However, long term over-voltage or reverse polarity will damage the unit.

Hazardous Area Earth

Terminal B on all ZBD Zener Barriers is a “Hazardous Area common connection” and should be connected to a good quality earth suitable for Intrinsically Safe equipment in accordance with the ATEX directive.

Maintenance

There are no components in the ZBD range which can be serviced, the ZBPD should be returned to EDL if servicing is required. Maintenance is restricted to ensuring that segregation is maintained (50mm minimum between Safe area and Hazardous area wiring) and that both input and output wiring connections remain in good condition.

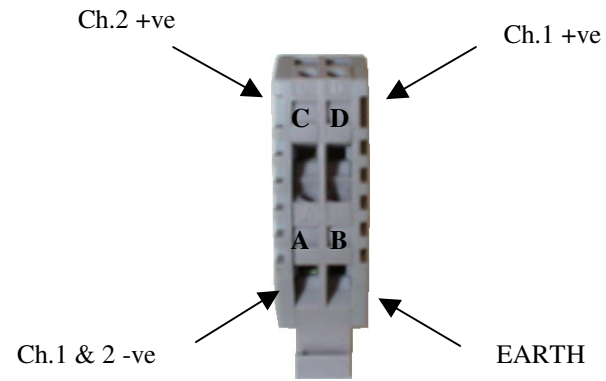

NOTE A and B are connected internally

**INPUT
CONNECTIONS**

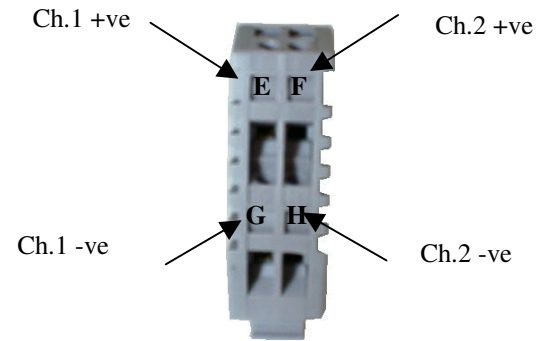

**OUTPUT
CONNECTIONS
HAZARDOUS AREA**

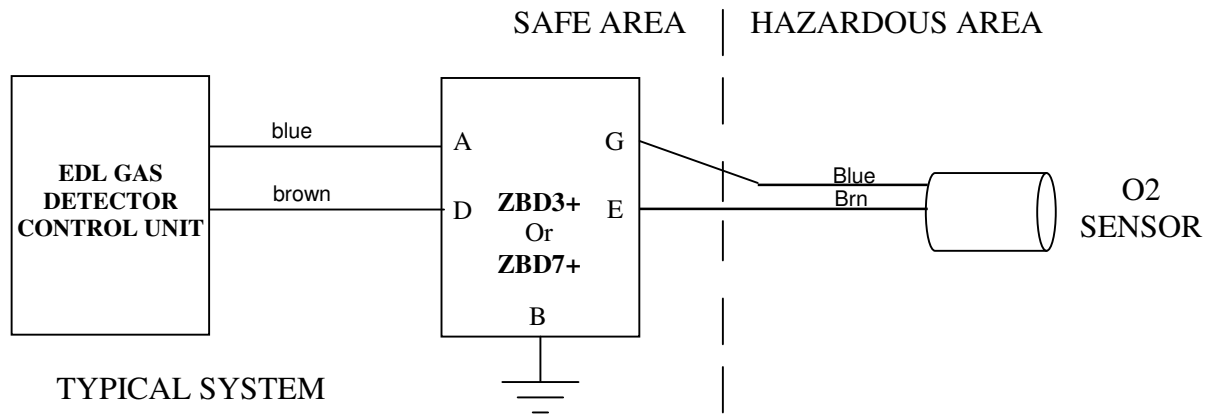

TYPICAL SYSTEM

MANUFACTURED BY	TITLE	NOTES	DRN. BY.	ISSUE	DATE	DWG. NO.
ELECTRONIC DEVICES LTD. ENIGMA HOUSE ENIGMA BUSINESS PARK MALVERN WR14 1GD	DIN RAIL MOUNTING ZENER BARRIER TYPE ZBD3 / 7 CONNECTIONS		MJC	1	10.1.06	ZBD3 / 7

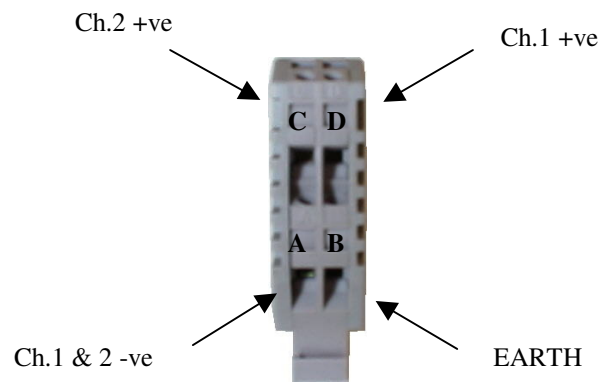

INPUT CONNECTIONS
SAFE AREA

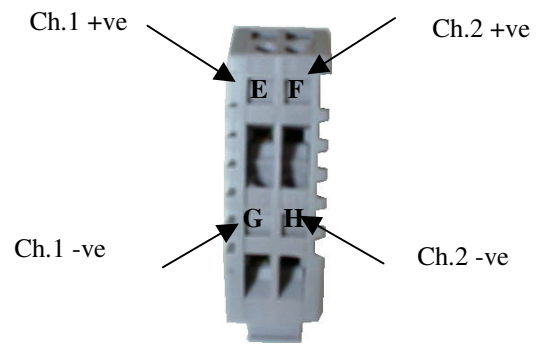

OUTPUT CONNECTIONS
HAZARDOUS AREA

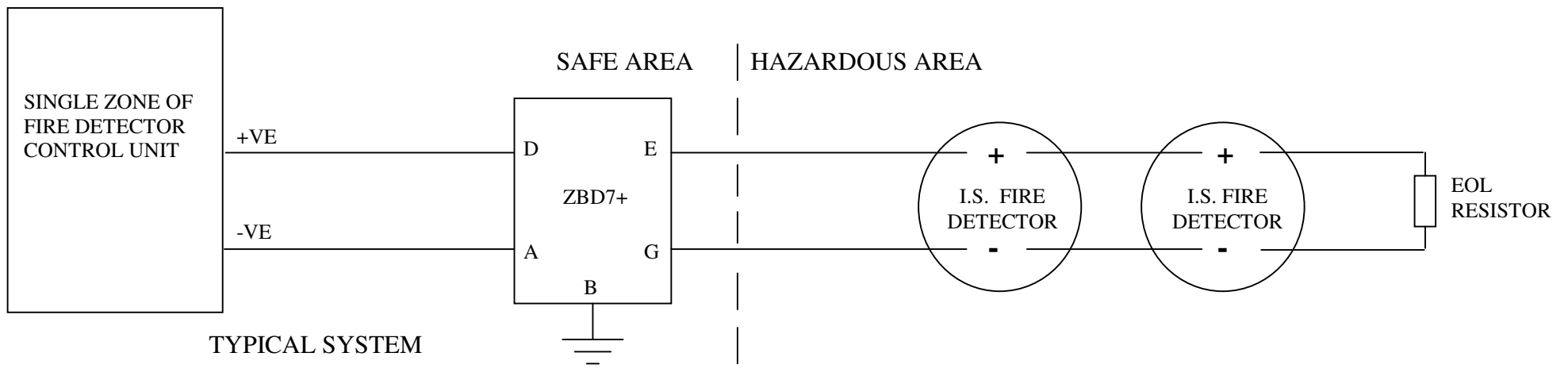

TYPICAL SYSTEM

MANUFACTURED BY	TITLE	NOTES	DRN. BY.	ISSUE	DATE	DWG. NO.
ELECTRONIC DEVICES LTD. ENIGMA HOUSE ENIGMA BUSINESS PARK MALVERN WR14 1GD	DIN RAIL MOUNTING ZENER BARRIER TYPE ZBD7+ CONNECTIONS	Each Barrier has two channels and can therefore be wired to two zones.	MJC	2	10.1.06	ZBD+ CON

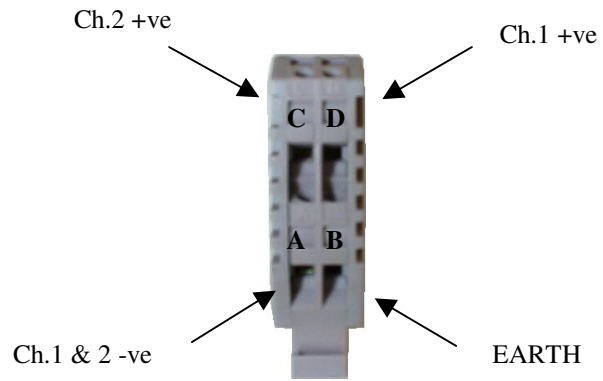

INPUT CONNECTIONS

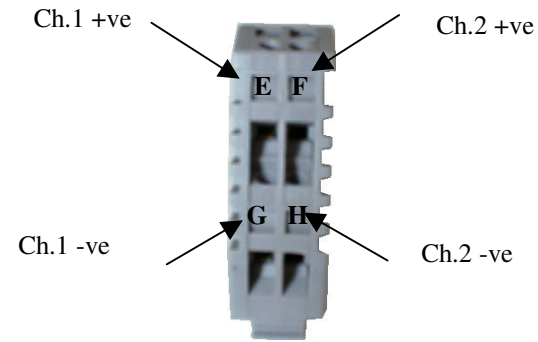

OUTPUT CONNECTIONS
HAZARDOUS AREA

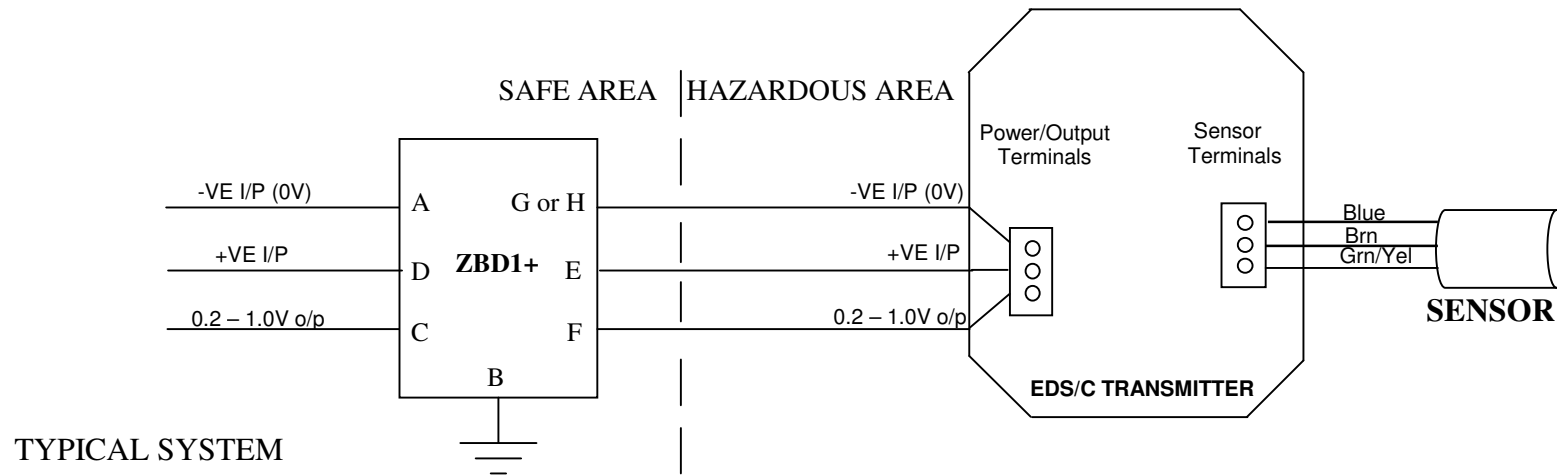

TYPICAL SYSTEM

MANUFACTURED BY	TITLE	NOTES	DRN. BY.	ISSUE	DATE	DWG. NO.
ELECTRONIC DEVICES LTD. ENIGMA HOUSE ENIGMA BUSINESS PARK MALVERN WR14 1GD	DIN RAIL MOUNTING ZENER BARRIER TYPE ZBD1+ CONNECTIONS		MJC	1	20.12.00	ZBD1 C2

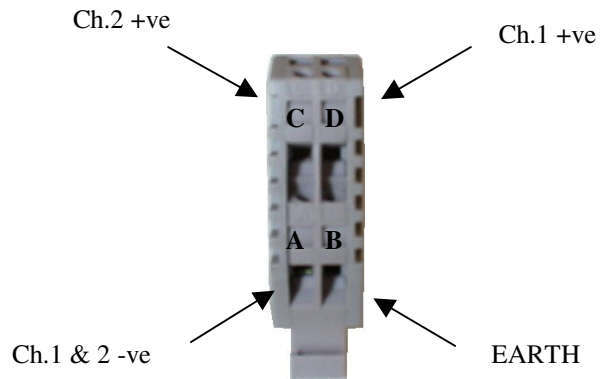

INPUT CONNECTIONS

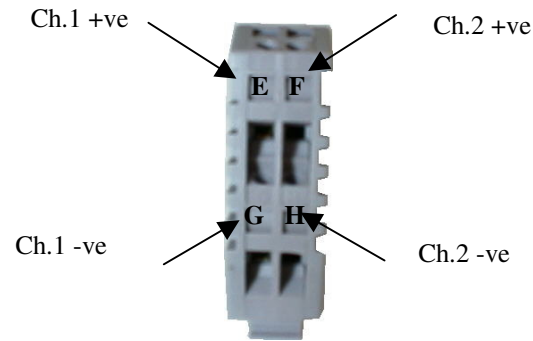

OUTPUT CONNECTIONS
HAZARDOUS AREA

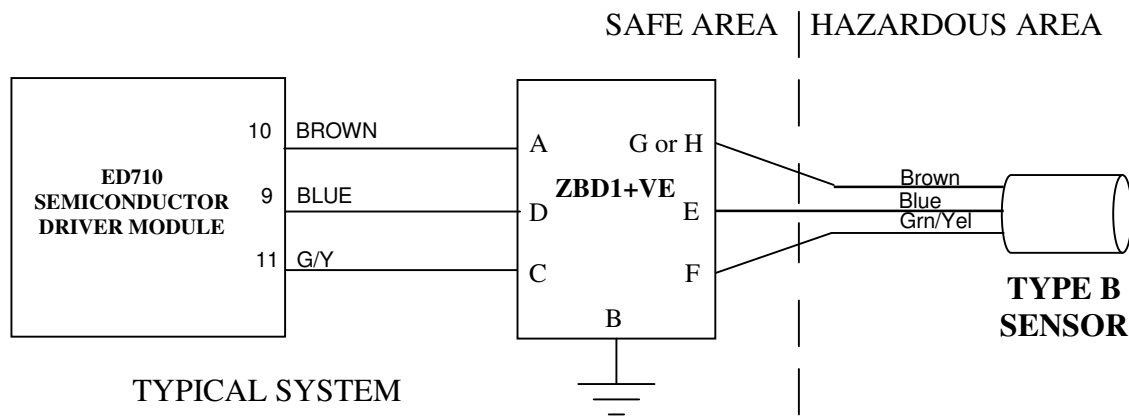

TYPICAL SYSTEM

NOTE

Before connecting sensor check barrier type and input connections. It is possible to connect a type B sensor to the ED710 using a ZBD1-VE however the connections are different. Please see diagram number ZBD1NC. Incorrect connection will damage the Zener Barrier.

MANUFACTURED BY	TITLE	NOTES	DRN. BY.	ISSUE	DATE	DWG. NO.
ELECTRONIC DEVICES LTD. ENIGMA HOUSE ENIGMA BUSINESS PARK MALVERN WR14 1GD	DIN RAIL MOUNTING ZENER BARRIER TYPE ZBD1+VE CONNECTED TO A TYPE B GAS SENSOR		MJC	1	14.11.05	ZBD1 PB

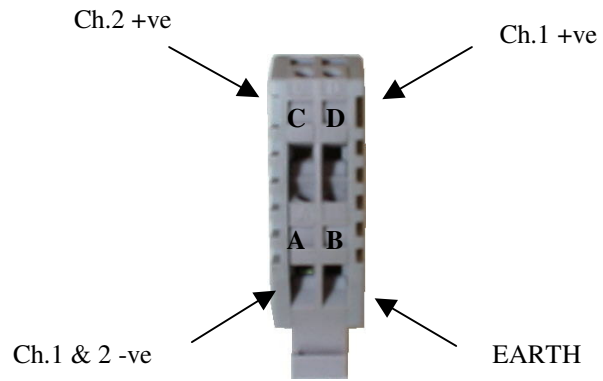

INPUT CONNECTIONS

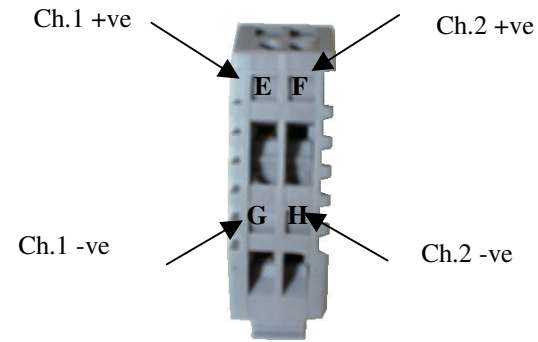

OUTPUT CONNECTIONS
HAZARDOUS AREA

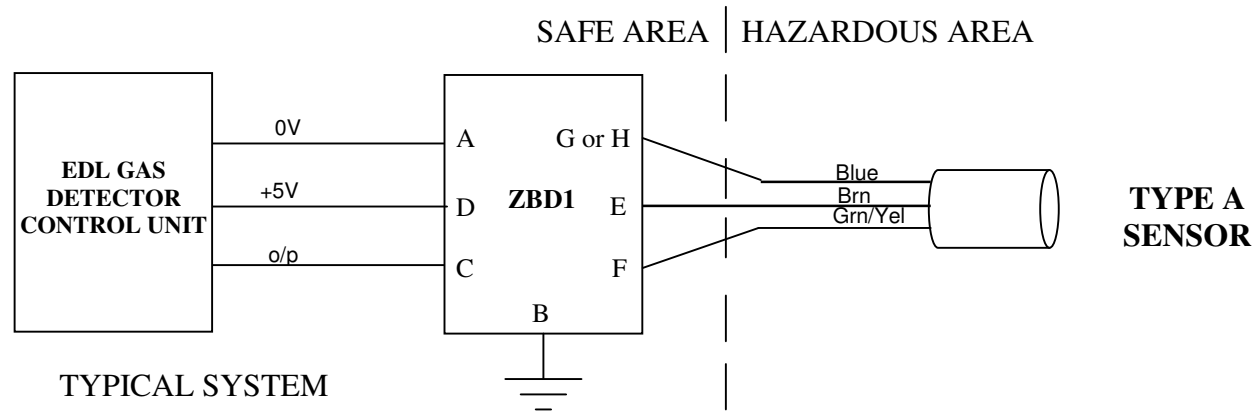

TYPICAL SYSTEM

MANUFACTURED BY	TITLE	NOTES	DRN. BY.	ISSUE	DATE	DWG. NO.
ELECTRONIC DEVICES LTD. ENIGMA HOUSE ENIGMA BUSINESS PARK MALVERN WR14 1GD	DIN RAIL MOUNTING ZENER BARRIER TYPE ZBD1 CONNECTIONS		MJC	1	20.12.00	ZBD1 CON

Please note the - DECLARATION OF CONFORMITY

And the ZBD EC-TYPE EXAMINATION CERTIFICATE

Graphics have been removed to reduce the size of the document for download purposes.

The full manual and certificates can be obtained by contacting Electronic Devices ltd.